

TYPE	A	B	C	D	E	F	G	H	J	K	L	M	N	P	R
TPS 50	42.75"	35.50"	13"	11"	5.50"	9"	14.50"	2"	4"	12"	8"	-	4.50"	7.50"	.75"
TPS 80	42.75"	35.50"	13"	11"	5.50"	7"	14.625"	4"	6"	12"	8"	-	6.625"	9.50"	.875"
TPS 100	52.25"	44.938"	13"	11"	5.50"	11.125"	18.625"	4"	8"	12"	8"	-	8.625"	11.75"	.875"
TPS 150	67.44"	58.125"	17"	19"	9.5"	12.875"	20.56"	6"	10"	16"	16"	-	10.75"	14.25"	1"

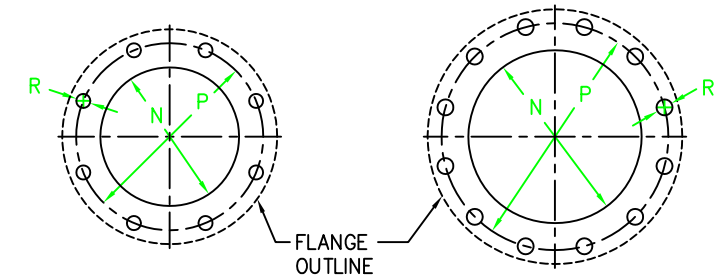

TANK CUT FOR  
TPS 50, TPS 80  
AND TPS 100

TANK CUT  
TPS 150

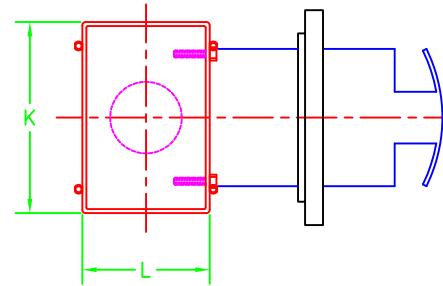
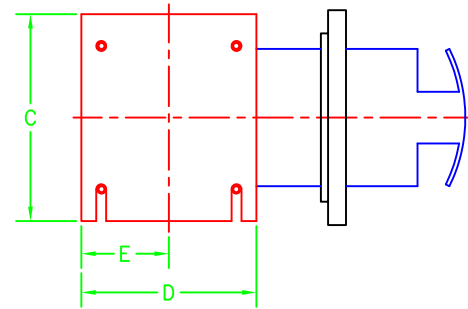
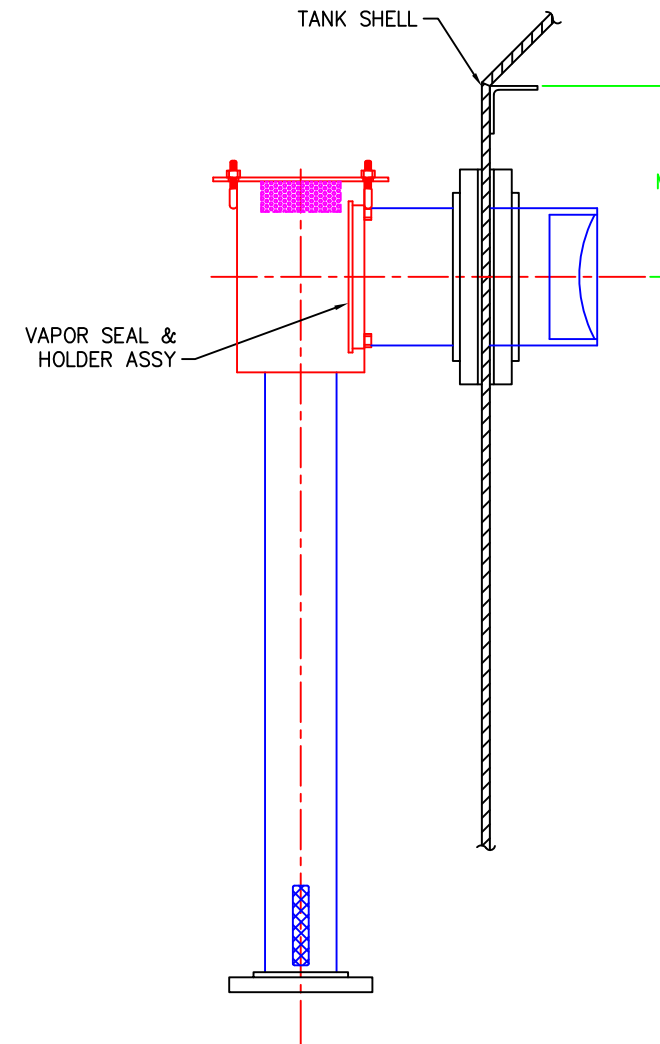
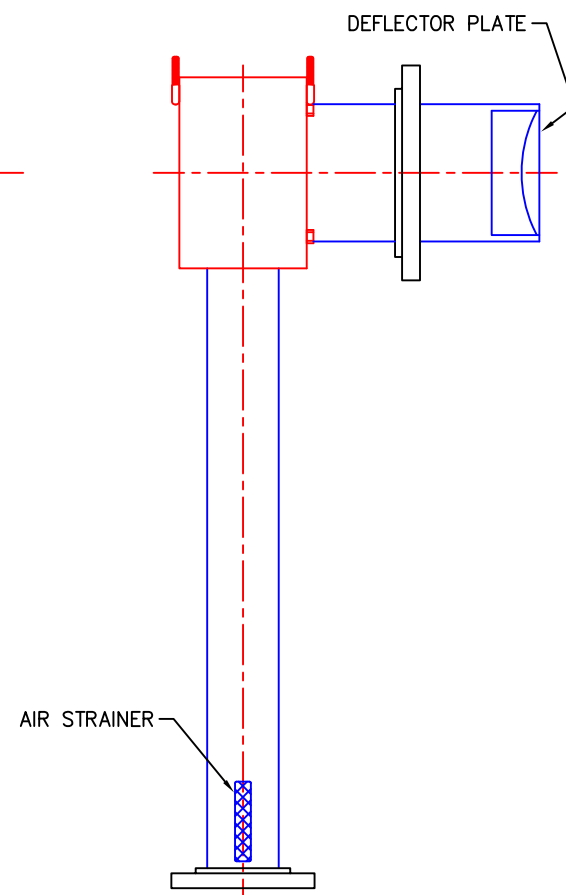
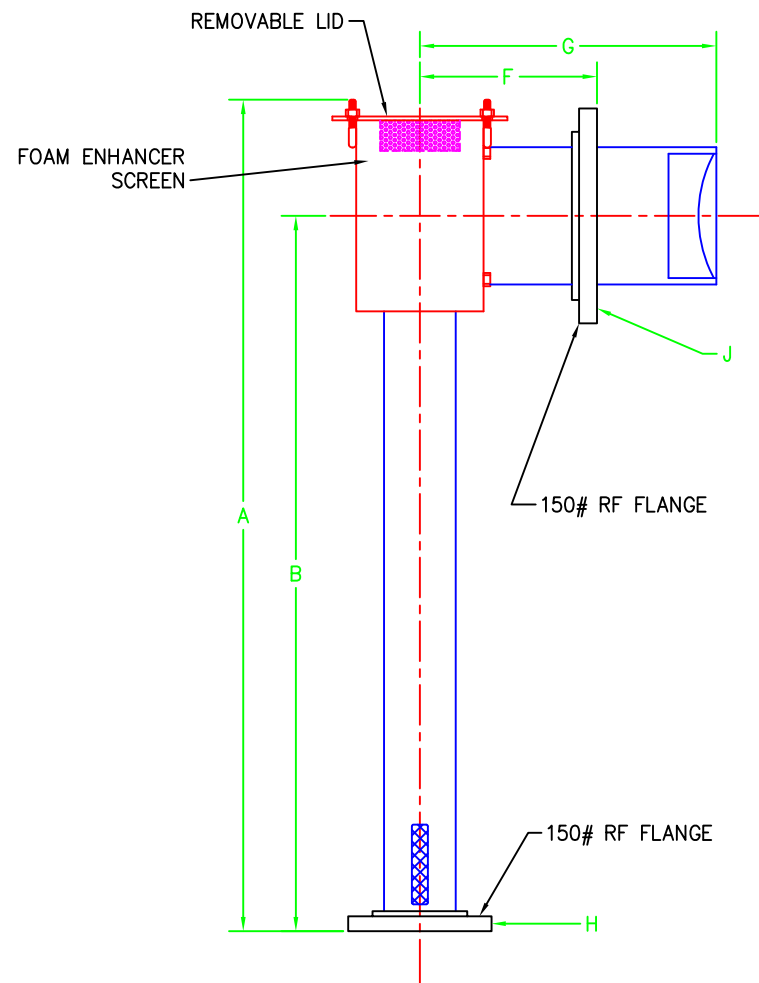

**QUALITY  
STARTS  
HERE**

**NOTICE**  
This drawing and the data thereon are confidential to and the proprietary property of Flameout. The drawing and the data thereon shall not be duplicated, or disclosed without the written permission of Flameout. All authorized reproductions shall bear this notice.

**Flameout**

**HOUSTON,  
TEXAS**



(713) 722-0952 FAX: (713) 464-0260

SCALE: NONE BP - NORTH AMERICA DRAWN BY: DAP  
DATE: 4/30/08 REVIEWED BY: MOORE

TPS FOAM CHAMBER  
DATA SHEET

APPROVAL:  
DATE: 4/30/08

DRAWING NUMBER  
CAB-P1A-01

**ALL DIMENSIONS TO BE FIELD VERIFIED.**