

FLAMEOUT DESIGN &
 FABRICATION LLC
 1701 BRITTMORE
 HOUSTON, TEXAS 77043
 sales@fdfeng.com

FLANGE RETAINER KITS

AVAILABLE IN:
CARBON STEEL (HDG ON REQUEST)
304 STAINLESS STEEL
316 STAINLESS STEEL
(MADE IN USA (AIS) UPON REQUEST)

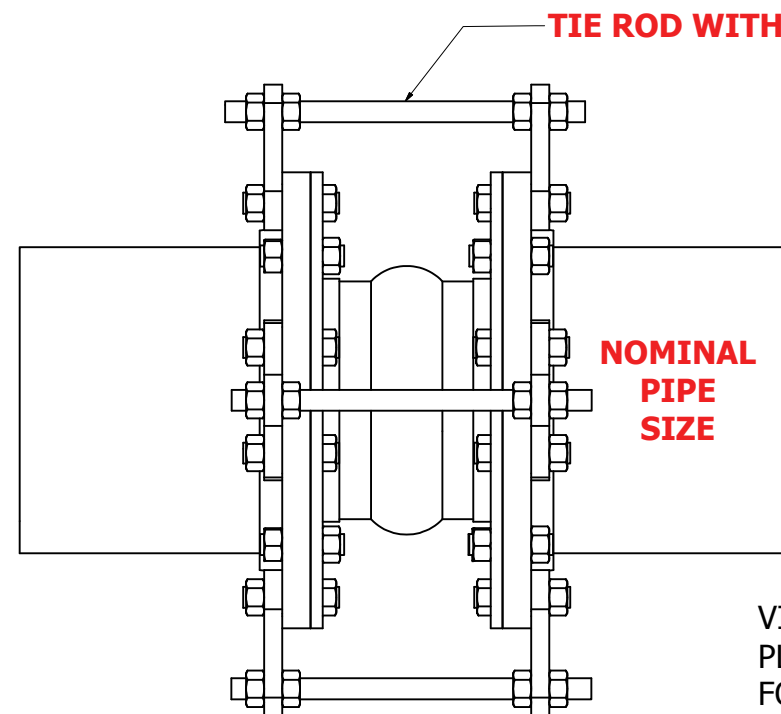

VIEW SHOWS 4 RETAINER KITS.
 PLEASE REFER TO SIZING CHART
 FOR NUMBER OF KITS REQUIRED
 FOR PIPE SIZE AND PRESSURE

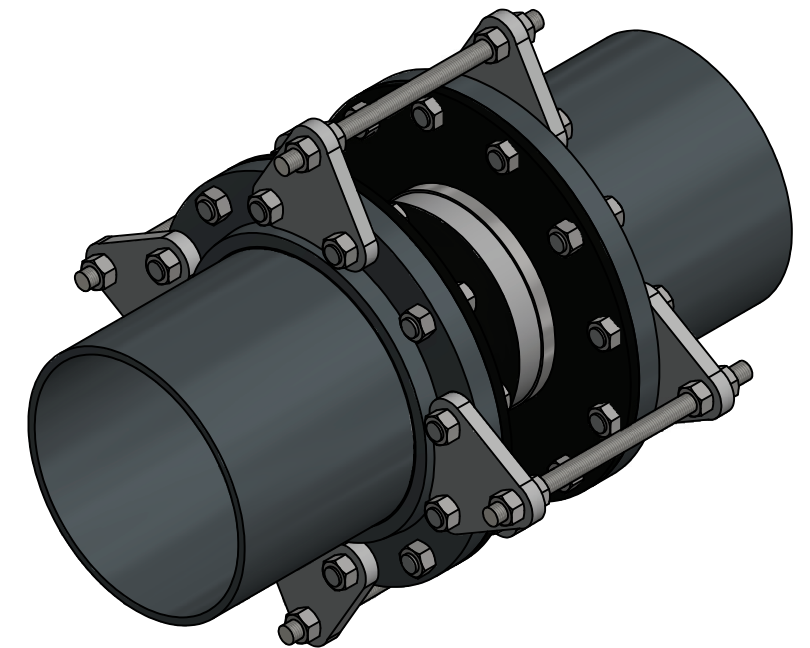
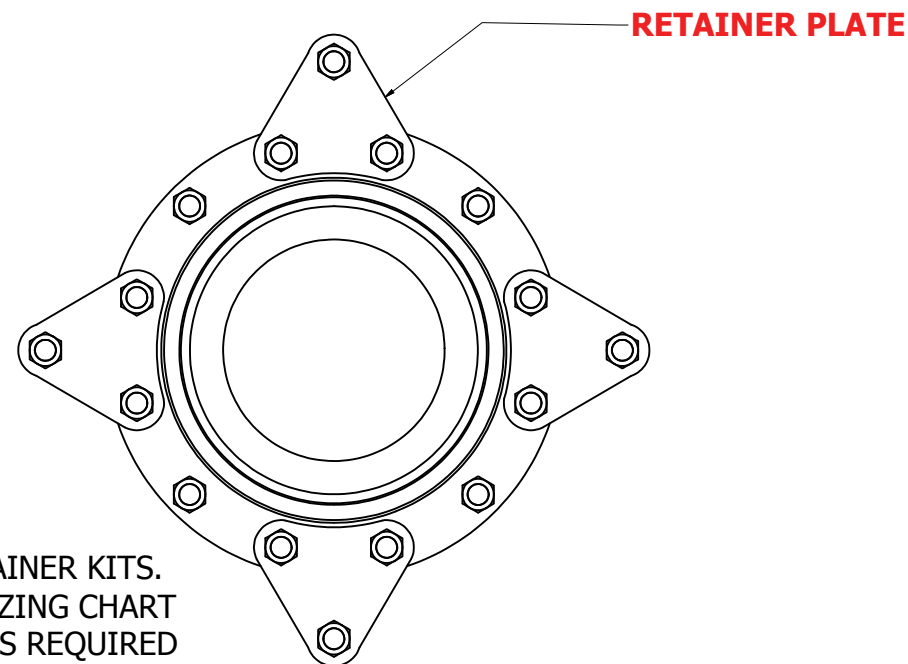

STANDARD DATA (FOR HIGH PRESSURE, ADDITIONAL RETAINERS MAY BE REQUIRED, SEE TABLE BELOW)											
NOMINAL PIPE SIZE	STD. CONTROL ROD NUMBER	STANDARD NUMBER RETAINER PLATES	THICKNESS IN INCHES	ROD DIAMETER IN INCHES	MAX. PRESSURE FOR 2 SET OF RETAINERS	MAX. PRESSURE FOR 3 SETS OF RETAINERS	MAX. PRESSURE FOR 4 SETS OF RETAINERS	MAX. PRESSURE FOR 6 SETS OF RETAINERS	MAX. PRESSURE FOR 8 SETS OF RETAINERS	STANDARDIZED ROD LENGTH IN INCHES	APPROXIMATE WEIGHT IN POUNDS
1.5	2	2	3/8	5/8	< 500 PSI	NA	NA	NA	NA	14	5
2	2	2	3/8	5/8	< 650 PSI	NA	NA	NA	NA	14	7
2.5	2	2	3/8	5/8	<525 PSI	NA	NA	NA	NA	14	8
3	2	2	3/8	5/8	< 440 PSI	NA	NA	NA	NA	14	8 1/2
4	2	2	3/8	5/8	< 300 PSI	< 465 PSI	< 620 PSI	NA	NA	14	8
5	2	2	3/8	5/8	< 230 PSI	< 350 PSI	< 465 PSI	NA	NA	14	9
6	2	2	1/2	5/8	< 180 PSI	< 275 PSI	< 370 PSI	NA	NA	14	11
8	2	2	1/2	7/8	< 160 PSI	< 240 PSI	< 325 PSI	NA	NA	18	14
10	2	2	3/4	7/8	< 160 PSI	< 240 PSI	< 325 PSI	< 485 PSI	NA	18	22
12	2	2	3/4	1 1/8	< 160 PSI	< 240 PSI	< 320 PSI	< 480 PSI	NA	18	27
14	2	2	3/4	1 1/8	< 110 PSI	< 165 PSI	< 220 PSI	< 330 PSI	NA	18	29
16	2	2	3/4	1 1/8	< 100 PSI	< 170 PSI	< 225 PSI	< 335 PSI	< 450 PSI	18	29
18	2	2	3/4	1 1/8	< 90 PSI	< 140 PSI	< 185 PSI	< 280 PSI	< 375 PSI	18	32
20	2	2	3/4	1 1/8	< 75 PSI	< 115 PSI	< 155 PSI	< 230 PSI	< 310 PSI	18	33
24	2	2	1	1 1/4	< 75 PSI	< 110 PSI	< 145 PSI	< 220 PSI	< 290 PSI	18	48
30	2	2	1	1 1/4	< 70 PSI	< 105 PSI	< 140 PSI	< 210 PSI	< 280 PSI	18	50
36	2	2	1 1/2	1 3/4	< 65 PSI	< 100 PSI	< 135 PSI	< 105 PSI	< 275 PSI	18	55

DRAWN MOORE	06/15/2016	FLAMEOUT DESIGN & FABRICATION
CHECKED RODIGO	06/18/2016	
QA		
MFG MOORE APPROVED	08/12/2016	
TITLE		FLANGE RETAINER KIT SIZING DATA
SIZE D	DWG NO FO-16-0001-MFG	
SCALE NONE		REV 3
SHEET 1 OF 1		